

Montageanweisung
Installation Instructions
Notice d'installation
Istruzioni per il montaggio

Instrucciones de montaje
Инструкция по монтажу
安装说明

(R) H6 (F) (R) H6-R H12-R
(R) H9 (F) (R) H9-R H6UZ
(R) H11 (F) (R) H11-R H9UZ
H12

02/97 AWA 123-707

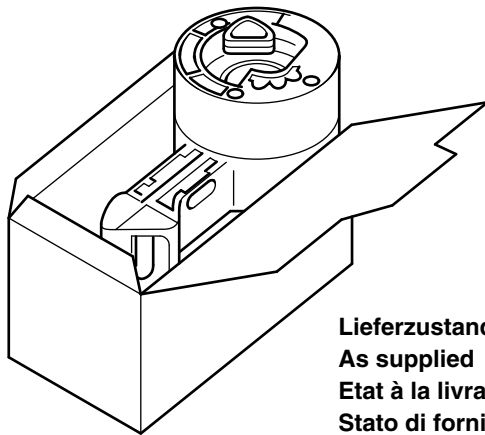

Lieferzustand
As supplied
Etat à la livraison
Stato di fornitura
Equipamiento

供货时的包装式样



Lebensgefahr durch elektrischen Strom!

Nur Elektrofachkräfte und elektrotechnisch unterwiesene Personen dürfen die im folgenden beschriebenen Arbeiten ausführen.

Electric current! Danger to life!

Only skilled or instructed persons may carry out the following operations.

Tension électrique dangereuse !

Seuls les personnes qualifiées et averties doivent exécuter les travaux ci-après.

Pericolo di morte causa corrente elettrica!

Solo persone istruite e avvertite possono eseguire le operazioni di seguito riportate.

¡Corriente eléctrica! ¡Peligro de muerte!

El trabajo a continuación descrito debe ser realizado por personas cualificadas y advertidas.

触电危险!

只允许专业人员和受过专业训练的人员进行下列工作。



Abschließbar durch Drehen des Griffes über die 0-Stellung hinaus.
Tür- bzw. Deckelverriegelung jetzt wirksam.

Lock by turning handle past 0-position.
Door or cover interlock is now effective.

Pour verrouiller la porte ou le capot, tourner la poignée jusqu'à la position 0.
Le verrouillage par cadénassage est maintenant possible.

Lucchettabile tramite rotazione della maniglia superando la posizione 0. Il bloccoporta è ora attivato.

Para enclavar la puerta o la tapa, girar la maneta hasta la pos. 0. EL enclavamiento, de esta modo, es posible por candado.

将把手拧过0位便可锁闭。门锁和盖琐即时起作用。

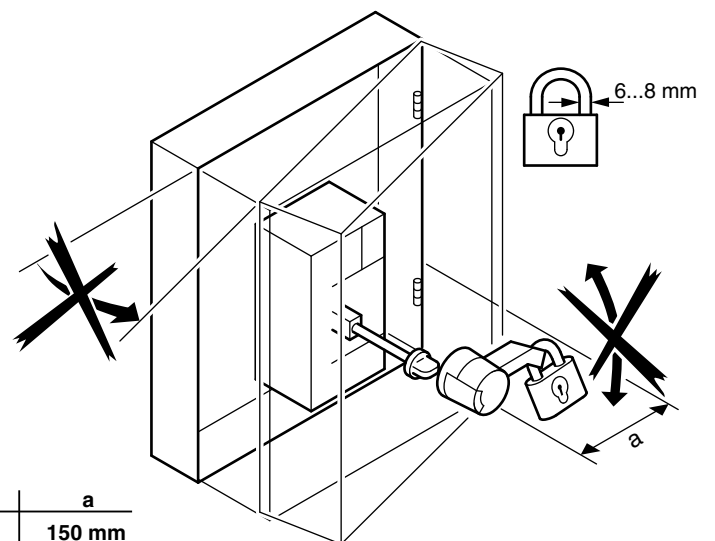
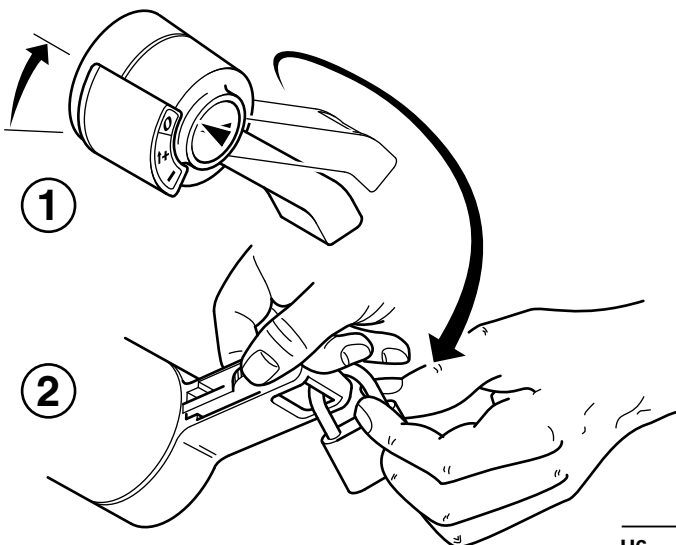

	a
H6	150 mm
H9,H11	180 mm
H12	210 mm

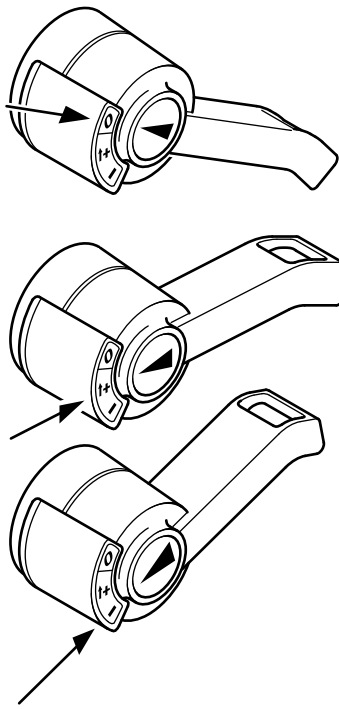

In allen weiteren Schaltstellungen nicht abschließbar.
Keine Tür- bzw. Deckelverriegelung wirksam.
Cannot be locked in any other position.
No effective door or cover interlock.
Verrouillage impossible dans toutes les autres positions.

Non si può lucchettare in nessun'altra posizione.
Non viene attivato il bloccoporta.
No es posible el enclavamiento en las otras posiciones
其它的位置不能锁闭。门锁和盖锁不起作用。

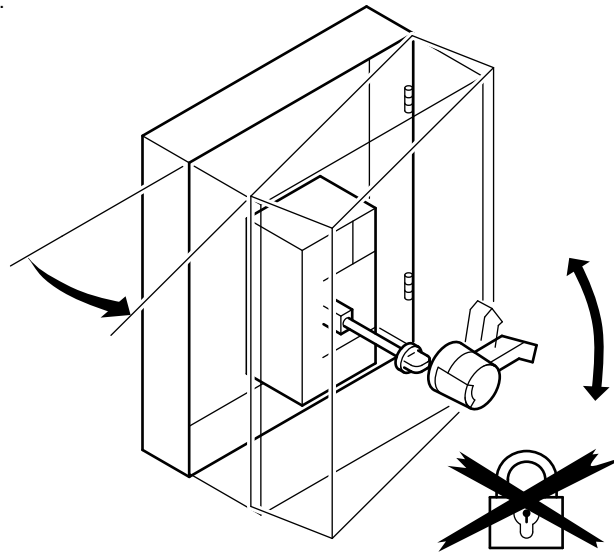

Veränderung der Abschließposition
Modifying the lockable position
Changement de la position de verrouillage
Modifica della posizione di lucchettabile
Cambio de la posición de enclavamiento
改变锁闭位置

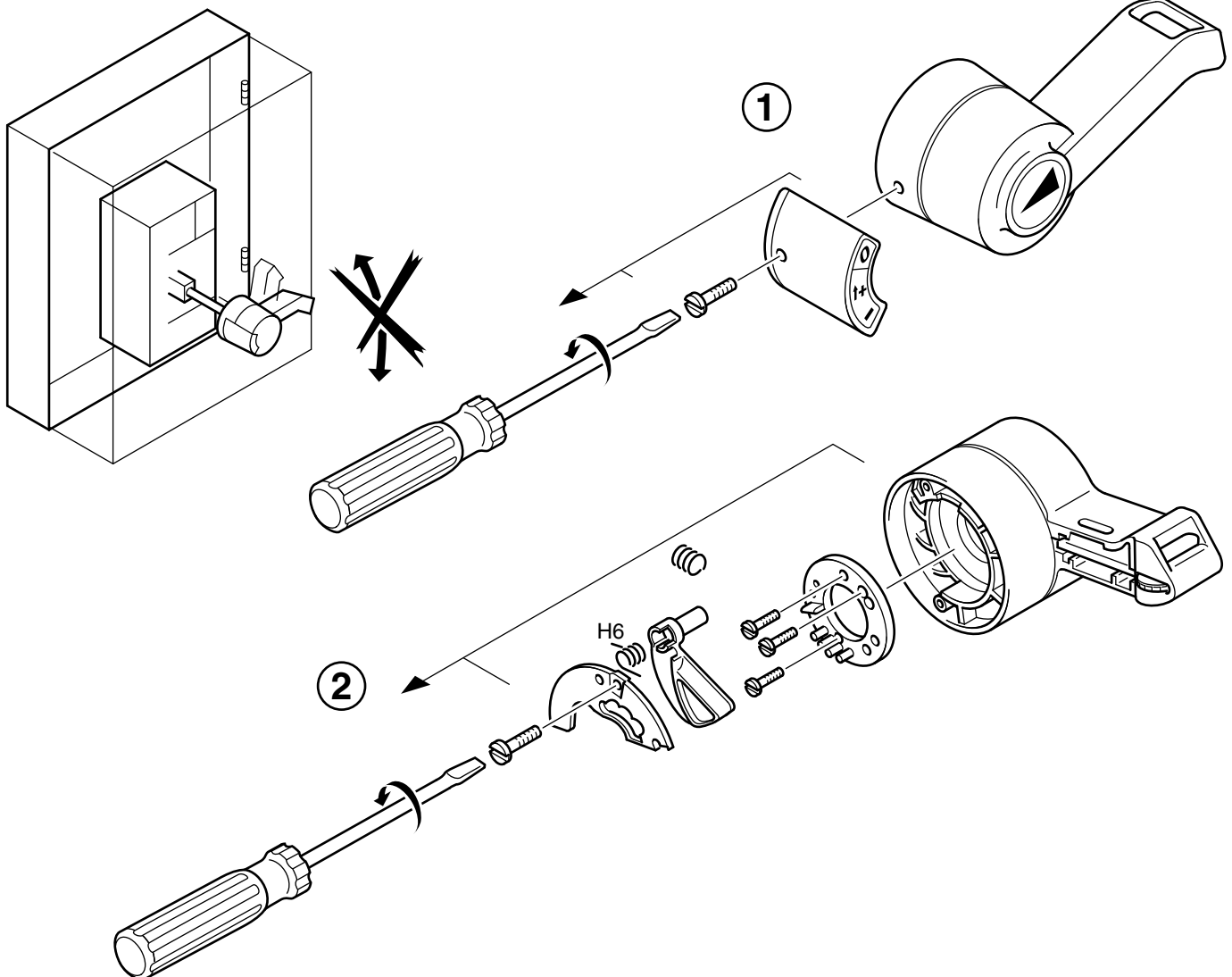

02/97 AWA 123-707

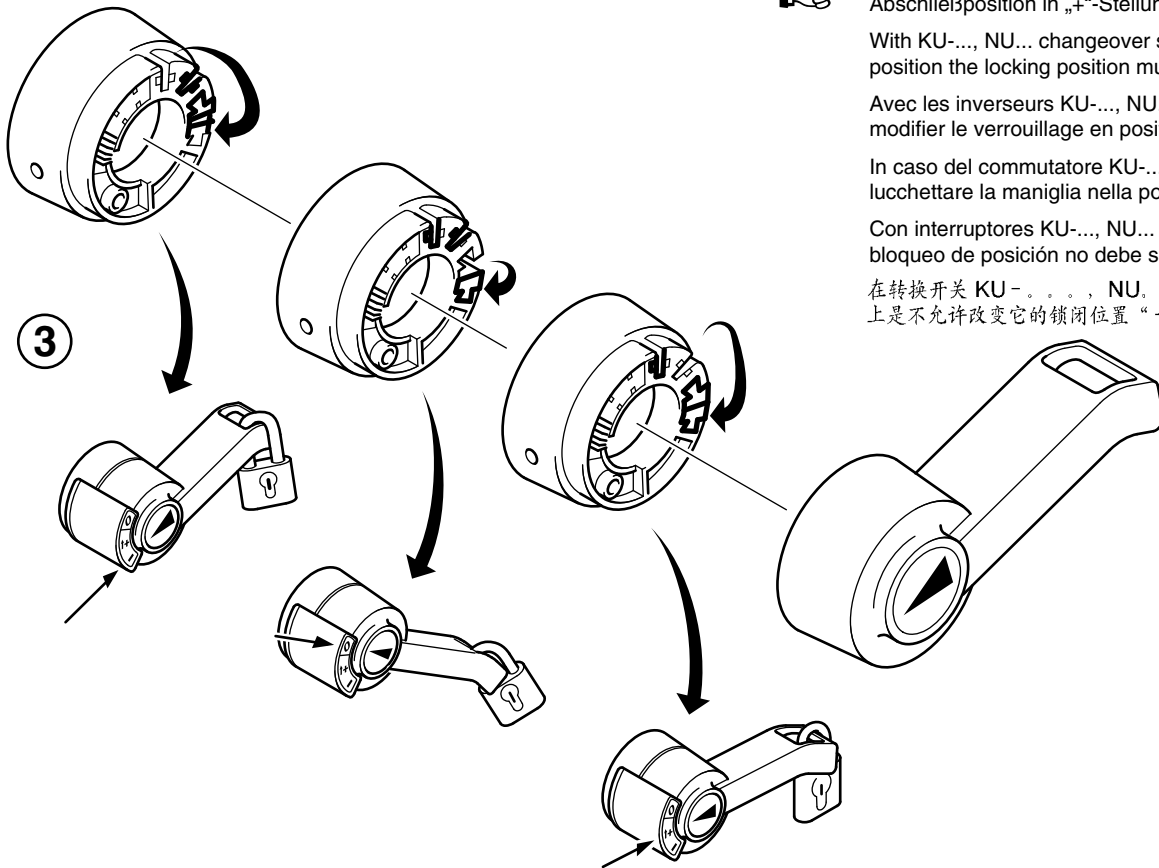

Bei Umschalter KU-..., NU... ist die Veränderung der Abschließposition in „+“-Stellung nicht zulässig.

With KU-..., NU... changeover switches in "+" position the locking position must not be modified.

Avec les inverseurs KU-..., NU..., il est interdit de modifier le verrouillage en position « + ».

In caso del commutatore KU-..., NU... è proibito lucchettare la maniglia nella posizione di trip "+".

Con interruptores KU-..., NU... en posición "+" el bloqueo de posición no debe ser modificado.

在转换开关 KU-..., NU... 上是不允许改变它的锁闭位置“+”的。

02/97 AWA 123-707

Nur / only / seulement / soltanto / solamente / 只是 : (R)H6..., H12...

Beim Zusammenbau D- bzw. NA-Version beachten!

Check on assembly whether D or NA version.

Lors du montage, tenir compte de la version (D ou NA).

Fare attenzione al montaggio se a norme IEC oppure NA!

En el montaje tener en cuenta la versión (norma IEC ó NA)

在组装时要注意分别是D型还是NA型。

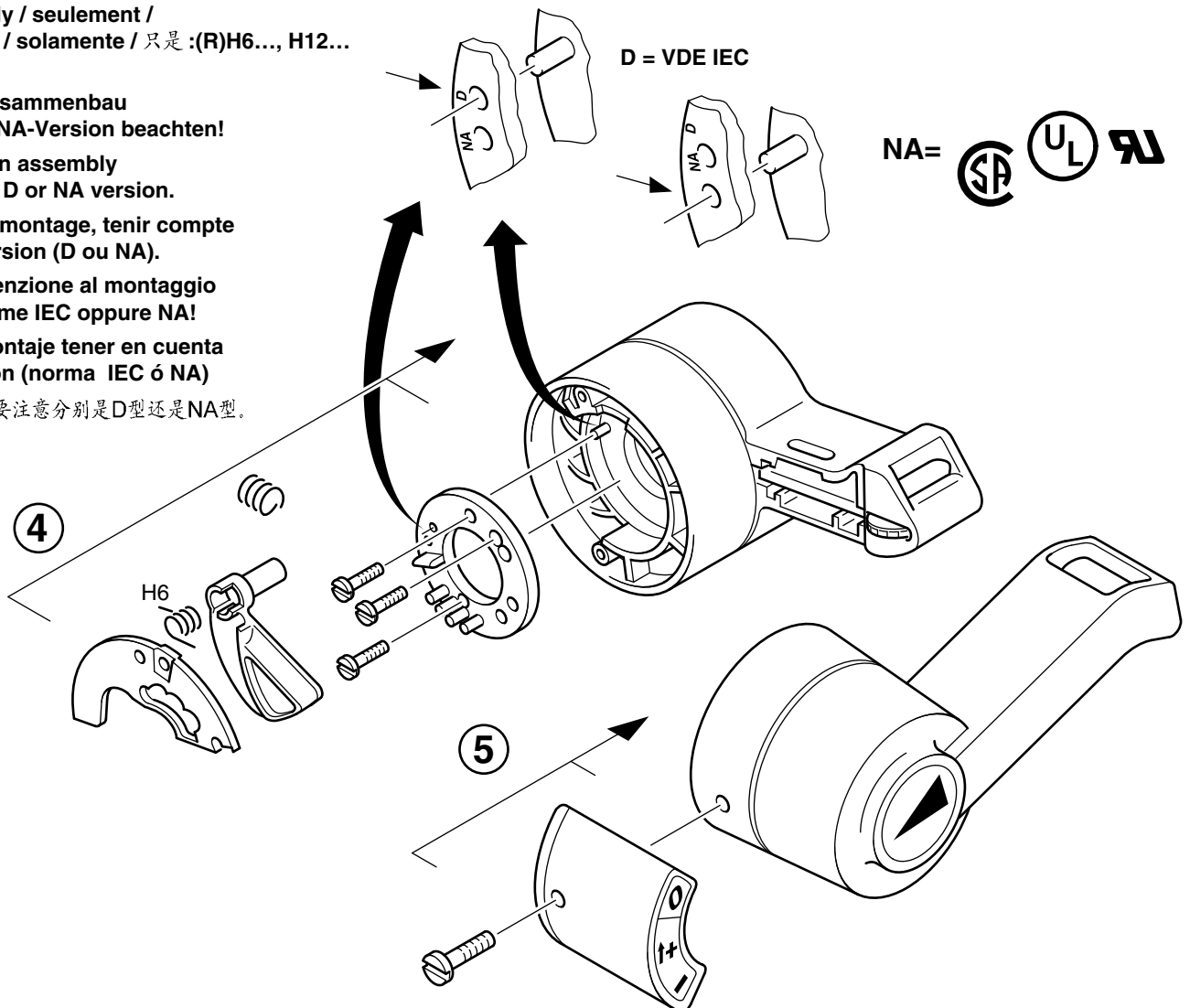

Tür- bzw. Deckelverriegelung
in + - und I-Stellung wirksam machen.

Make door or cover interlock effective
in + - and I positions.

Possibilité de verrouillage de porte
ou de capot en position + et I.

Possibilità di attivare il bloccoporta
nella posizione + e I.

Posibilidad de enclavamiento de la
puerta o de la tapa en la posición + y I.

在 + - 和 I 位置上将门锁和盖锁调灵。

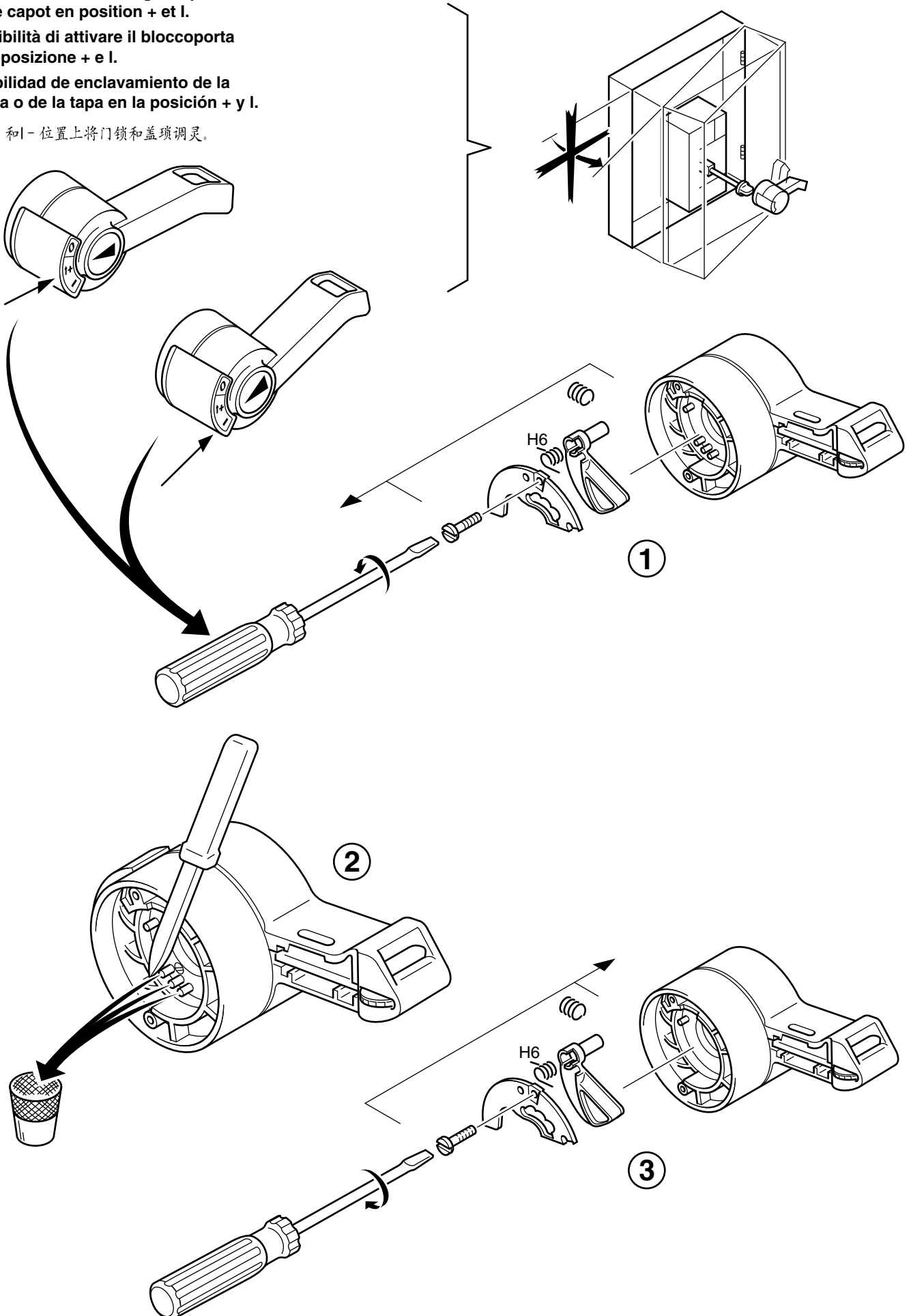

02/97 AWA 123-707

Deckelverriegelung in I-Position aufheben
Bypass interlock in I-position
Annulation du verrouillage en position I
Disattivare il bloccoporta nella posizione I
Anulación del enclavamiento en la posición I
在I-位置上取消盖锁的锁闭功能

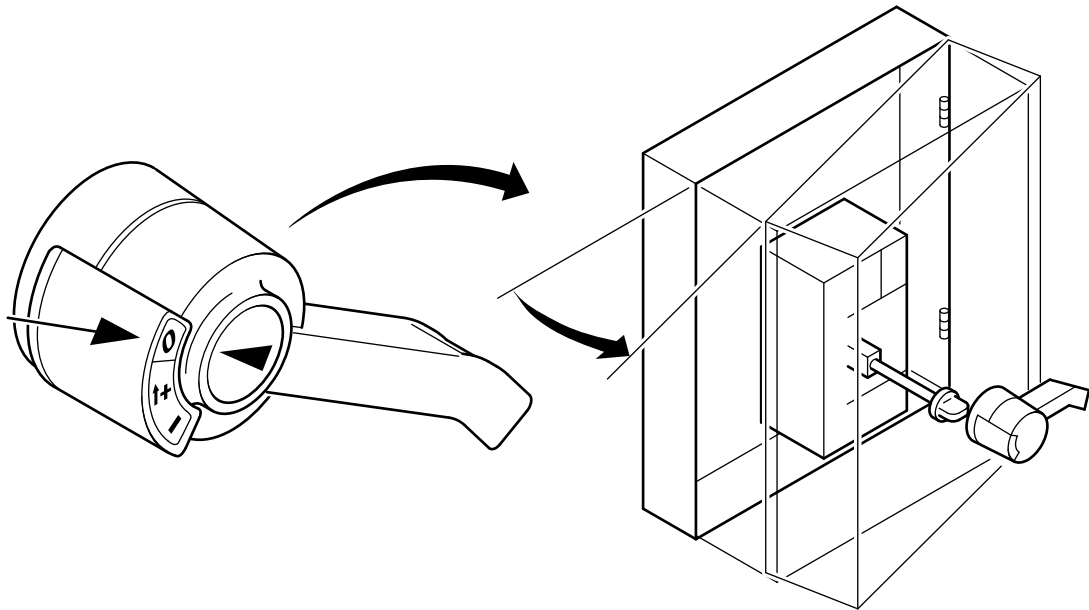
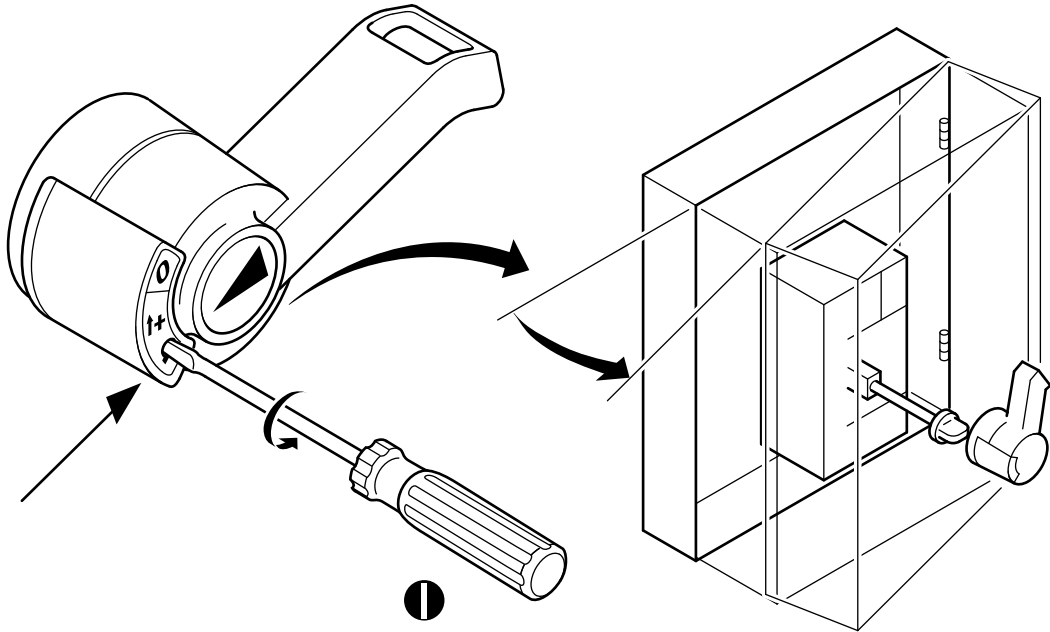

02/97 AWA 123-707

1

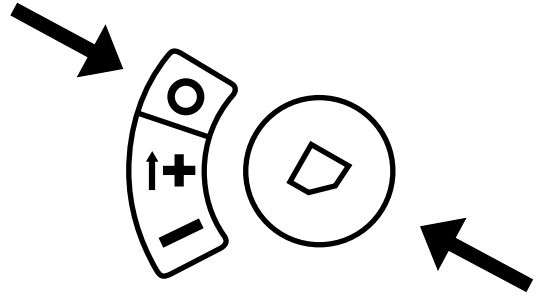
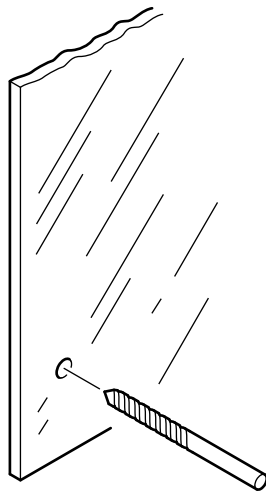
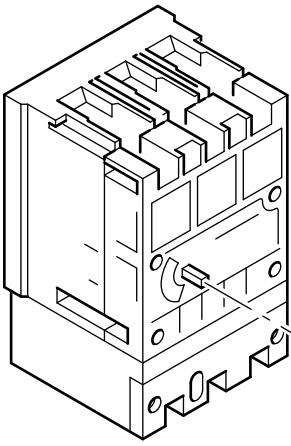

Nur Only
Seulement NZM12
Solo Sólo
这样

2

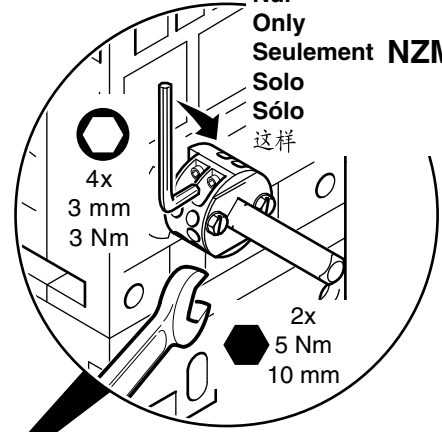
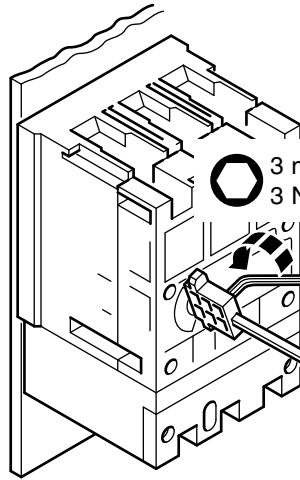
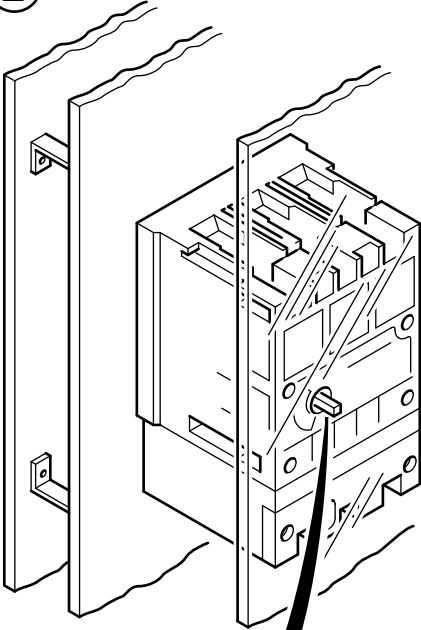

3 mm
3 Nm

2x
5 Nm
10 mm

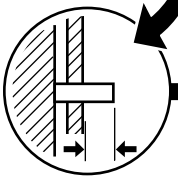

NZM (H) 4	8-11 mm
N (ZM) 6 (4)	8-11 mm
NZM (H) 6 (4)/ZM 6 (4)	8-11 mm
N (ZM) 9 (4)	8-12 mm
NZM (H) 9 (4)/ZM 9 (4)	8-12 mm
N (ZM) 11 (4)	8-12 mm
NZM (H) 11 (4)/ZM 11 (4)	8-12 mm
N (ZM) 12	8-13 mm
NZM 12 (4)/ZM 12 (4) (V)	8-13 mm

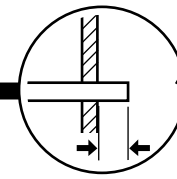

3

H9UZ
H10UZ
H12UZ

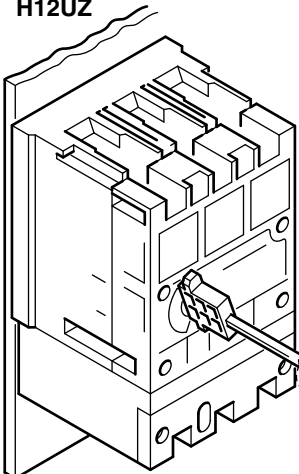

2

1,7 Nm

H6UZ

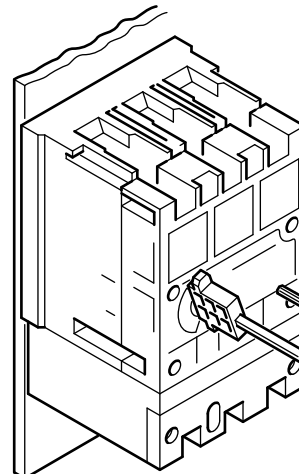

3 mm

1,7 Nm

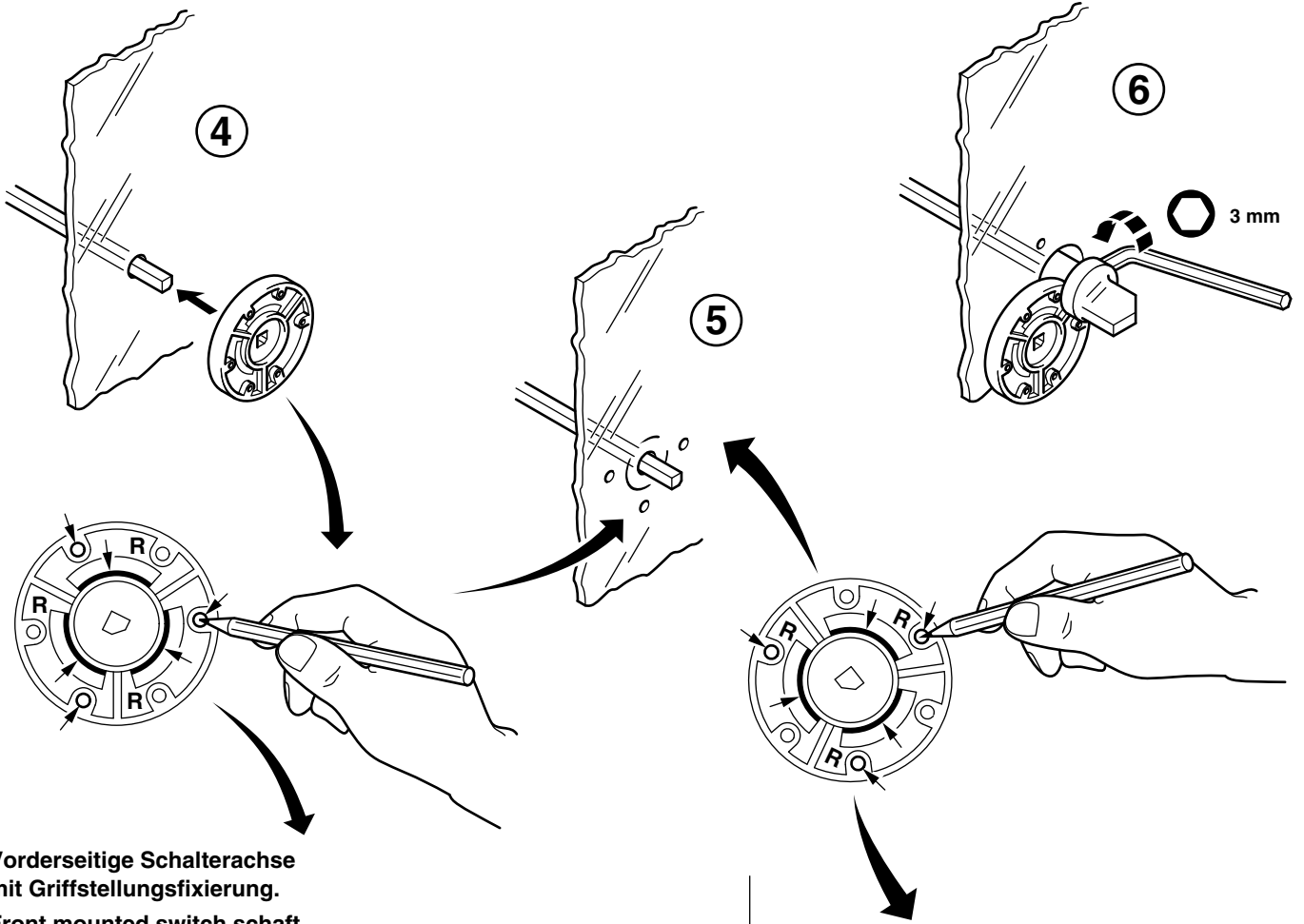

**Vorderseitige Schalterachse
mit Griffstellungsfixierung.**

**Front mounted switch shaft
with positive handle location.**

**Axe monté en face avant avec dispositif de
blocage de la position de la poignée.**

**Albero dell'interruttore montato frontalmente con
determinazione della posizione della maniglia.**

**Eje montado en la cara anterior con dispositivo
de enclavamiento de la posición de la maneta.**

前操作轴带有把手固定位置。

Rückseitige Schaltachse

Rear mounted switch shaft

Axe monté en face arrière

Albero dell'interruttore montato posteriormente

Eje montado en la cara posterior

后操作轴

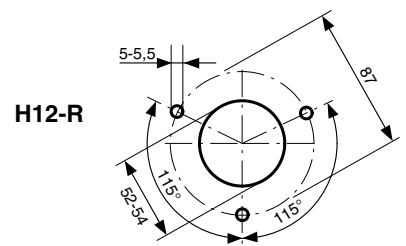
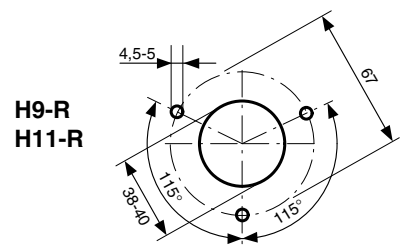
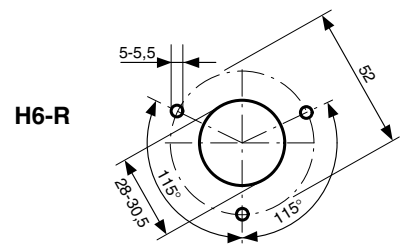
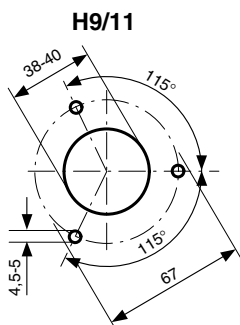
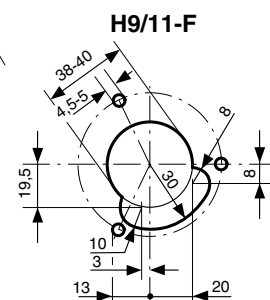
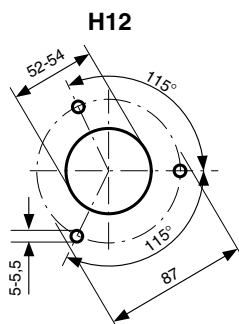
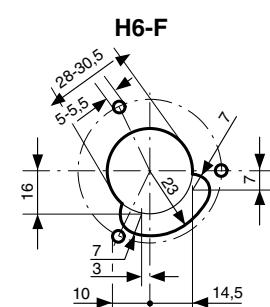
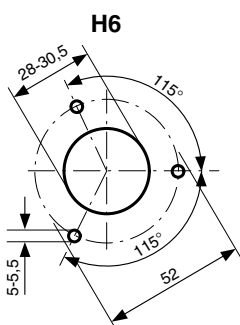

Bei durchsichtigen Isolierstofftüren
Schild dahinter montieren.

On transparent doors, fit label
behind door.

Sur les coffrets avec porte ou capot transparent,
monter la plaquette de repérage (imprimée ou
gravée) derrière la porte ou le capot.

Sulle antine trasparenti la targhetta va
montata all'interno.

En los armarios con puerta o tapa transparente
montar la placa indicadora detrás de la puerta.

将牌子装在透明的绝缘门后

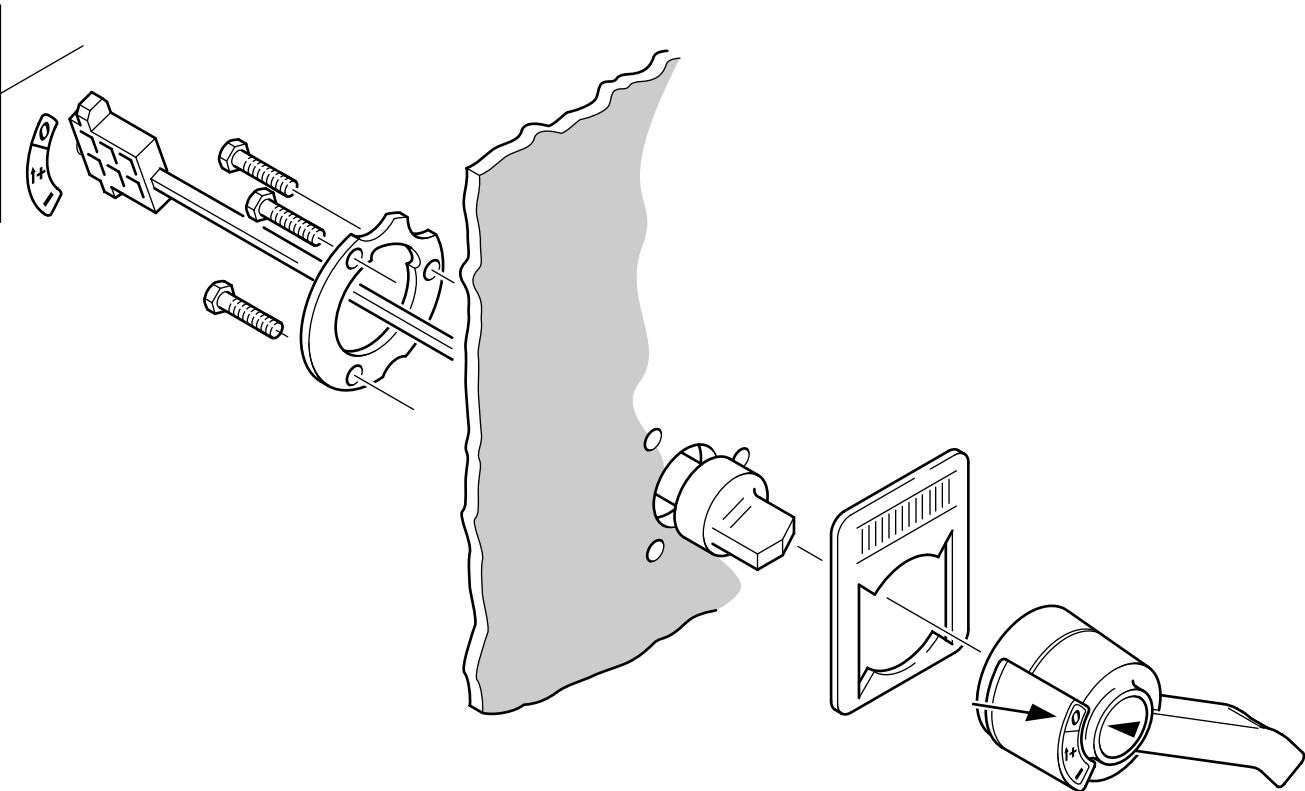
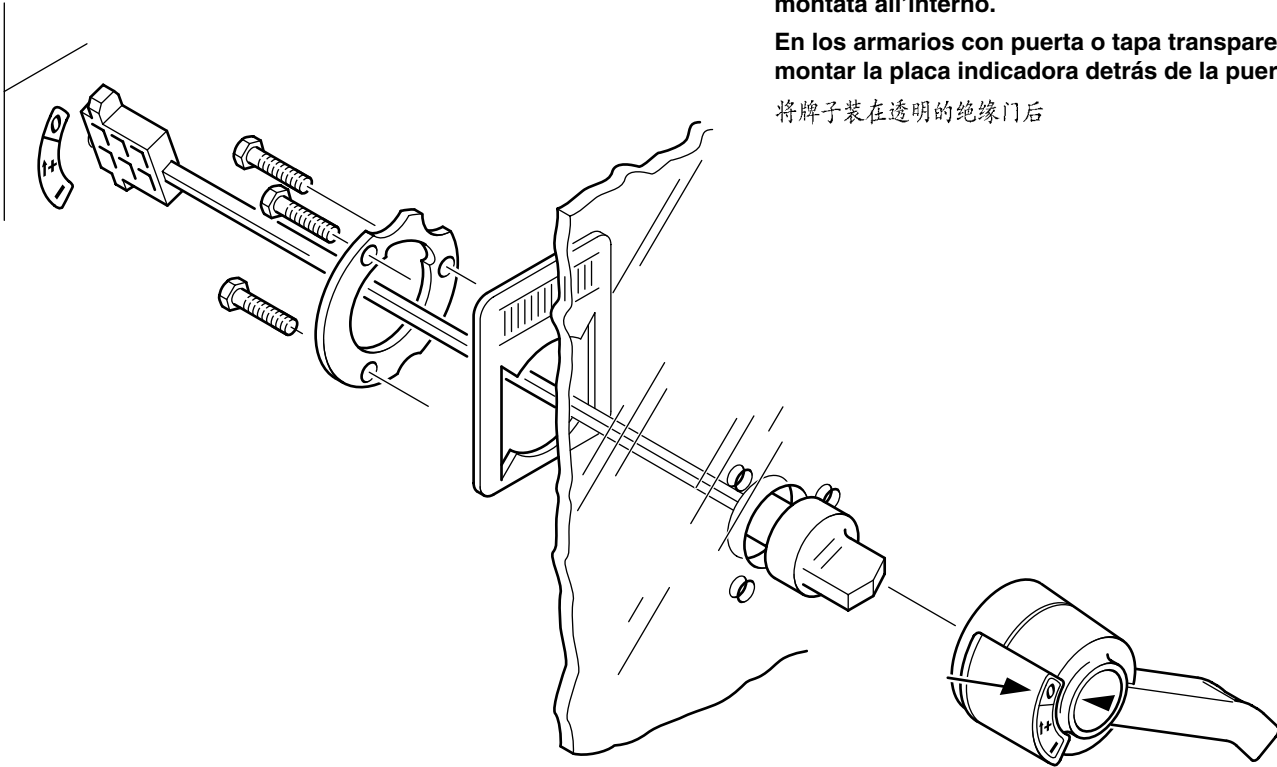

02/97 AWA 123-707