

A600-NZM 10

3/94 AWA 123-1283

Benötigtes Montagewerkzeug
 Necessary assembly tools
 Outils de montage nécessaires

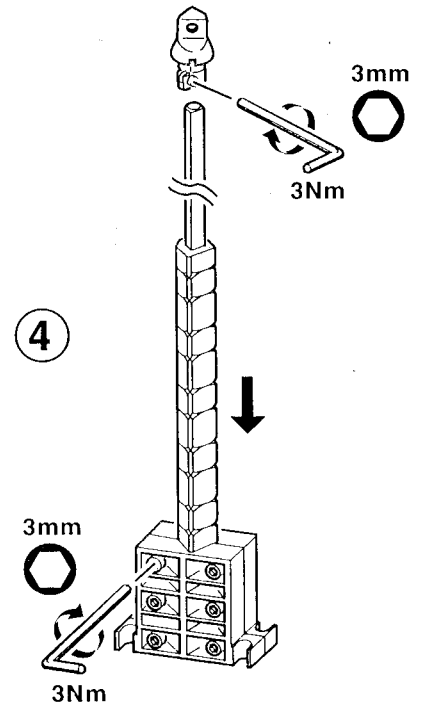
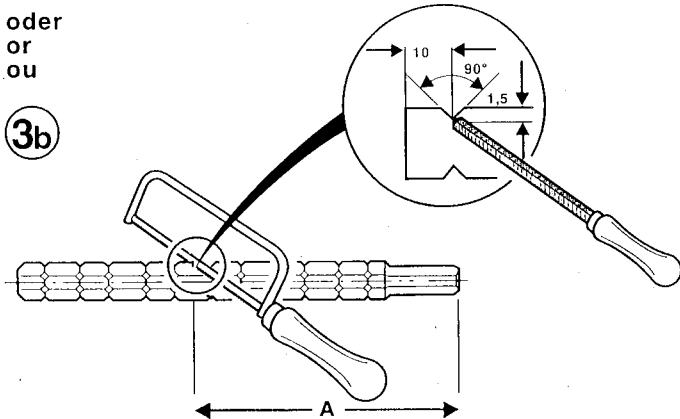
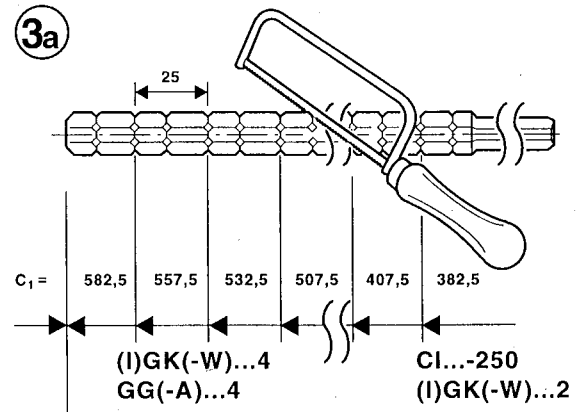
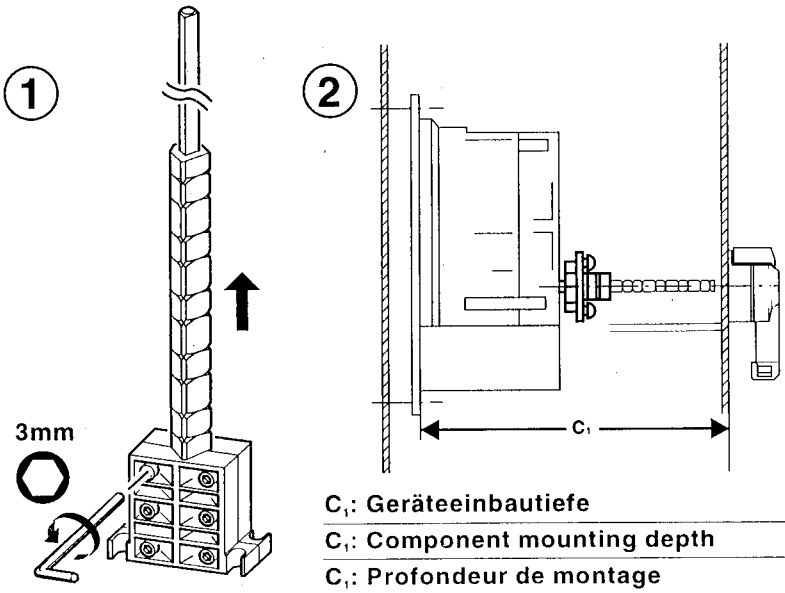
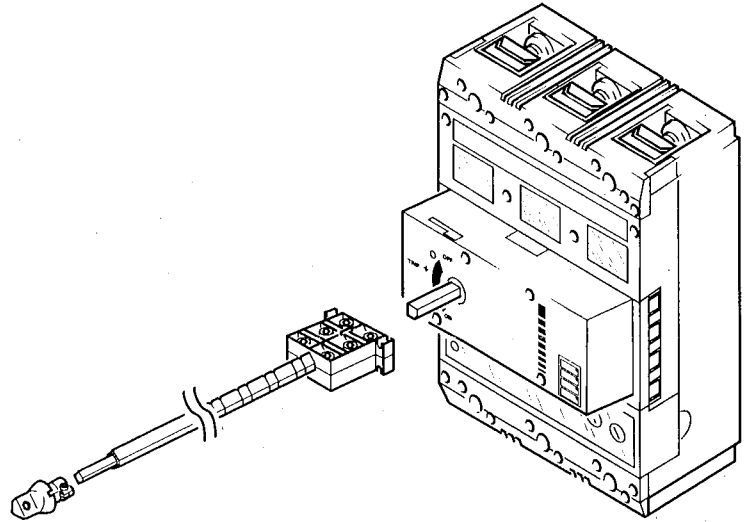
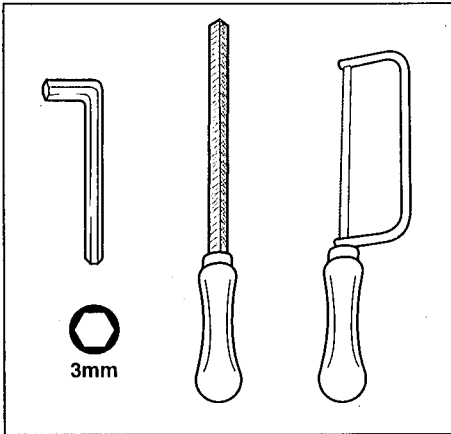

A: Achslänge = $C_1 - B$

A: Length of shaft = $C_1 - B$

A: Longueur de l'axe = $C_1 - B$

	N(ZM)9	N(ZM)11	NZM10,P10
B	186,5mm	208,5mm	173,5mm

Formel D
 9616