

NZM4(-4)-XKM1, NZM4(-4)-XKM2, NZM4(-4)-XKM2S

Module Plate Connector Kits for NZM4 Molded Case Circuit Breakers and Switches



Vorsicht!

Für die Durchführung der beschriebenen Arbeiten kann das Entfernen oder der Austausch von Teilen notwendig sein.
Bitte alle Installations-Anweisungen beachten, um die erforderlichen Luft- und Kriechstrecken nach dem Zusammenbau zu gewährleisten.

Caution!

The removal or exchange of parts during mounting may become necessary.
Refer to installation instructions for proper assembly and to maintain electrical clearances.

Attention !

L'enlèvement ou l'échange de certaines pièces pendant le montage est parfois nécessaire.
Consultez l'instruction d'assemblage pour assurer une installation conforme aux normes.

小心!

执行所描述的操作时可能需要拆除或更换零部件。
请遵守所有相关的安装说明，
以确保在组装后能获得需要的空间距离或爬电距离。

Attenzione!

Per l'esecuzione degli interventi descritti potrebbe essere necessaria la rimozione o sostituzione di alcuni pezzi.
Attendersi alle istruzioni d'installazione per garantire dopo l'assemblaggio le vie di dispersione necessarie.

Atención!

Con el fin de llevar a cabo los trabajos descritos, puede ser necesario eliminar o cambiar alguna pieza.
Le rogamos tenga en cuenta todas las instrucciones de instalación para así garantizar las líneas de fuga y efluvio necesarias tras el montaje.

Осторожно!

При проведении описанных процедур может возникнуть необходимость демонтировать или заменить детали.
Для обеспечения надлежащих зазоров и вывода тока утечки, соблюдайте все инструкции по монтажу.



Lebensgefahr durch elektrischen Strom!

Nur Elektrofachkräfte und elektrotechnisch unterwiesene Personen dürfen die im Folgenden beschriebenen Arbeiten ausführen.

Electric current! Danger to life!

Only skilled or instructed persons may carry out the following operations.

Tension électrique dangereuse !

Seules les personnes qualifiées et averties doivent exécuter les travaux ci-après.

Tensione elettrica: Pericolo di morte!

Solo persone abilitate e qualificate possono eseguire le operazioni di seguito riportate.

¡Corriente eléctrica! ¡Peligro de muerte!

El trabajo a continuación descrito debe ser realizado por personas cualificadas y advertidas.

Электрический ток! Опасно для жизни!

Только специалисты или проинструктированные лица могут выполнять следующие операции.

触电危险!

只允许专业人员和受过专业训练的人员进行下列工作。

1

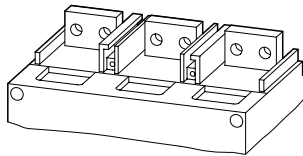

2

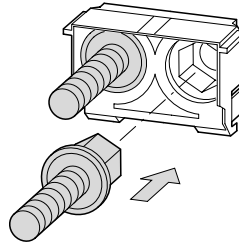

3

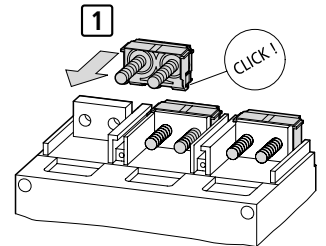

M10 metric size hardware, provided with all kits, connects to double hole per phase configuration on NZM4 breaker or switch.

4a

NZM4(-4)-XKM1

Single hole Module Plate Connector
M10 metric size

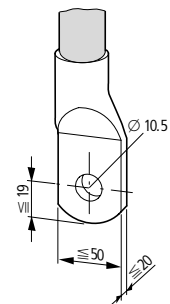
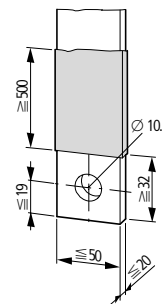
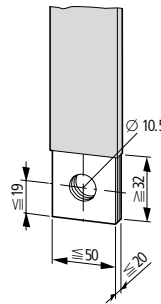
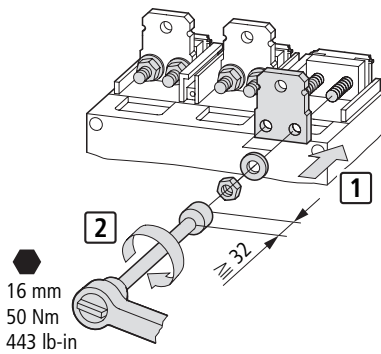

2 × (10 × 50 × 1) mm	2 × (50 × 10) mm	1 × (120 – 300) mm
		2 × (95 – 300) mm
		1 × (250 – 600 kcmil)
		2 × (AWG 3/0 – 600 kcmil)

4b

NZM4(-4)-XKM2

Double hole Module Plate Connector
M10 metric size

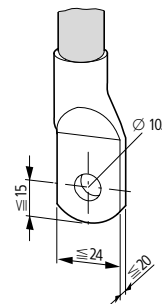
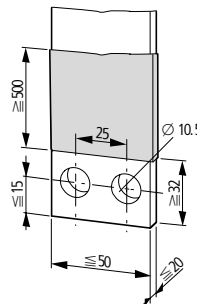
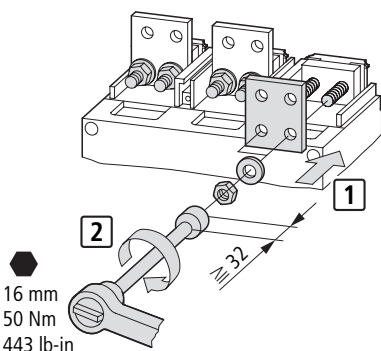

2 × (50 × 10) mm	2 × (95 – 185) mm
	4 × (35 – 185) mm
	2 × (AWG 3/0 – 350 kcmil)
	4 × (AWG 2 – 350 kcmil)

4c

NZM4(-4)-XKM2S
Double hole Module Plate Connector
M12 metric size

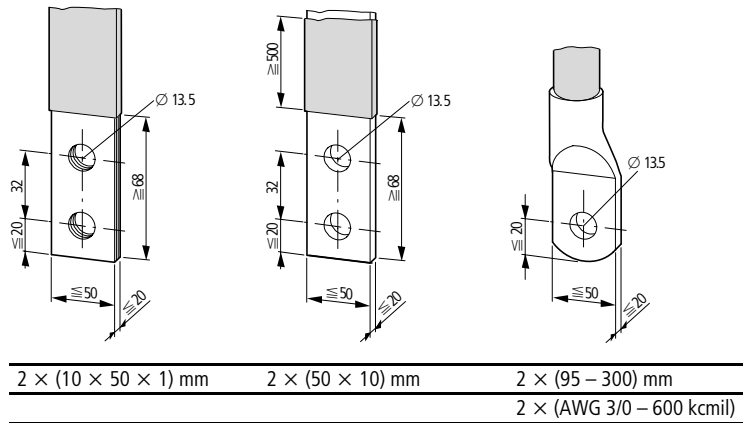
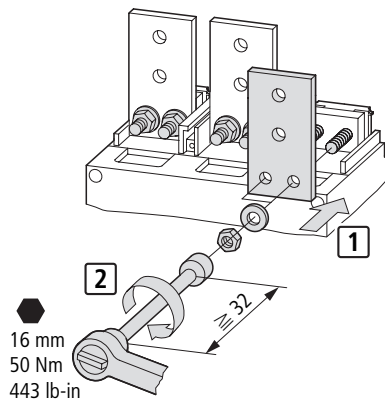

+NZM4-XKP

1) Phase Barriers for use with Module Plate Connector kits

5a

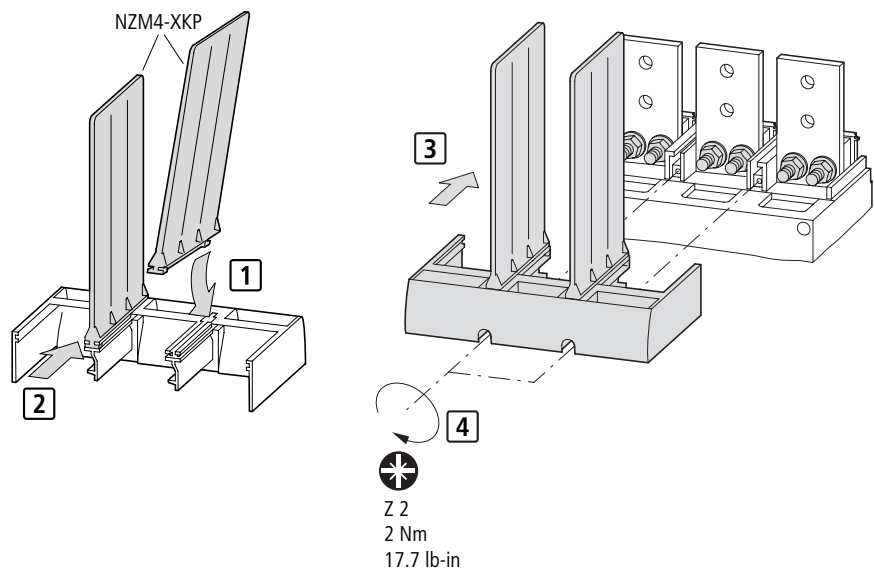
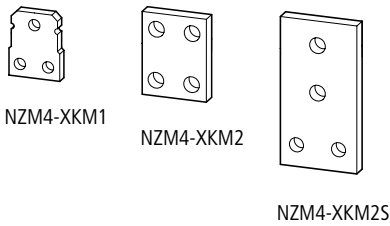

+NZM4-XKSA

1) Terminal Cover for use with Module Plate Connector kits

5b

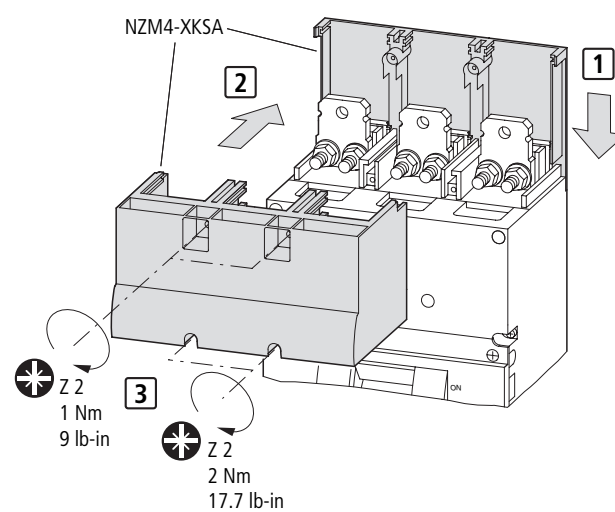
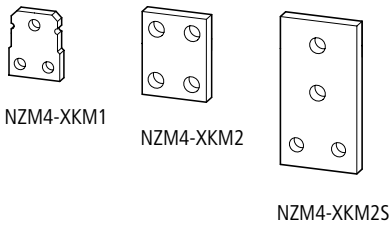

! Use of either the NZM4-XKP Phase Barriers, or the NZM4-XKSA Terminal Cover, is required at all times to maintain proper electrical clearances when using any of the NZM4-XKM... Module Plate Connector kits.