

NZM3-XT(V)D(V)(R)-0(-NA)



Lebensgefahr durch elektrischen Strom!
Nur Elektrofachkräfte und elektrotechnisch unterwiesene Personen dürfen die im Folgenden beschriebenen Arbeiten ausführen.

Electric current! Danger to life!
Only skilled or instructed persons may carry out the following operations.

Tension électrique dangereuse !
Seules les personnes qualifiées et averties doivent exécuter les travaux ci-après.

Tensione elettrica: Pericolo di morte!
Solo persone abilitate e qualificate possono eseguire le operazioni di seguito riportate.

¡Corriente eléctrica! ¡Peligro de muerte!
El trabajo a continuación descrito debe ser realizado por personas cualificadas y advertidas.

Электрический ток! Опасно для жизни!
Только специалисты или проинструктированные лица могут выполнять следующие операции.

触电危险!
只允许专业人员和受过专业训练的人员进行下列工作。

1

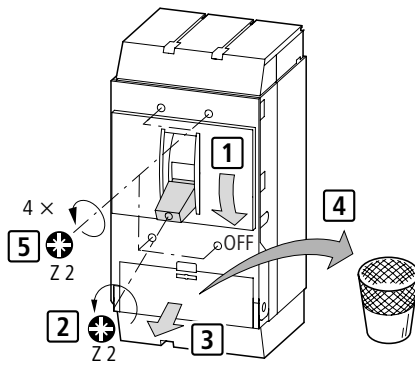

2

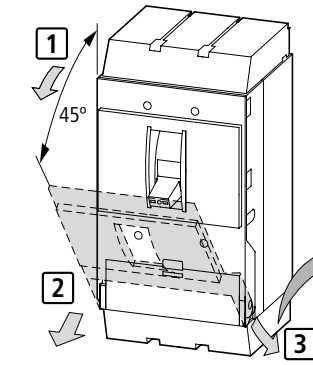

3

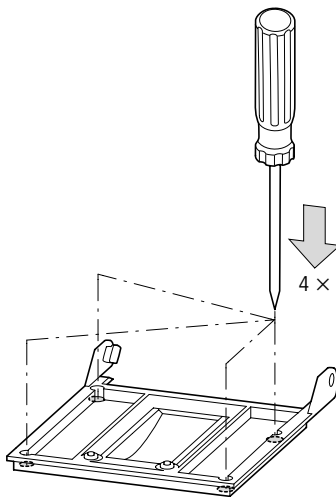

4

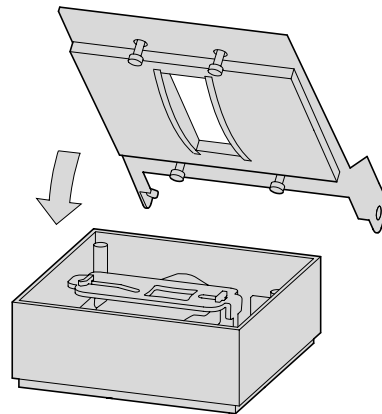

5

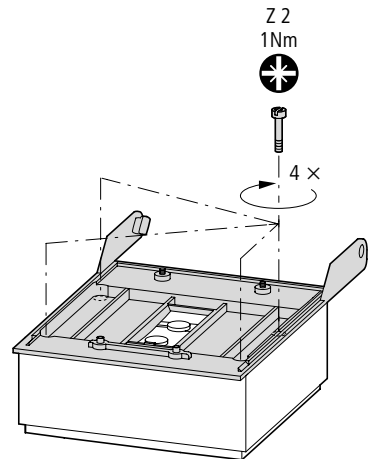

6

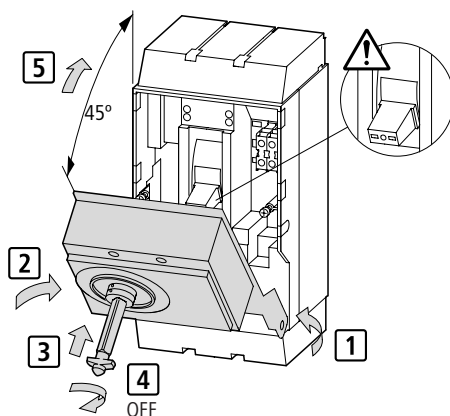

7

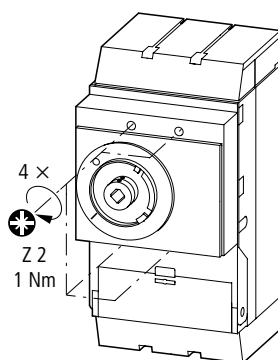

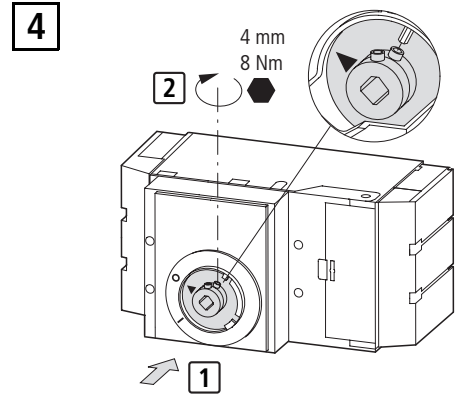
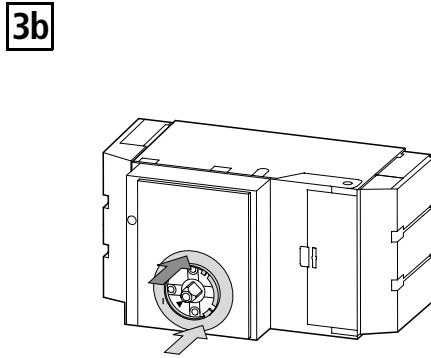
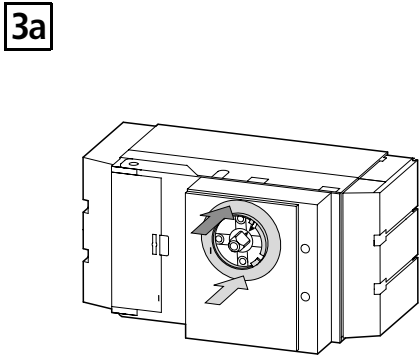
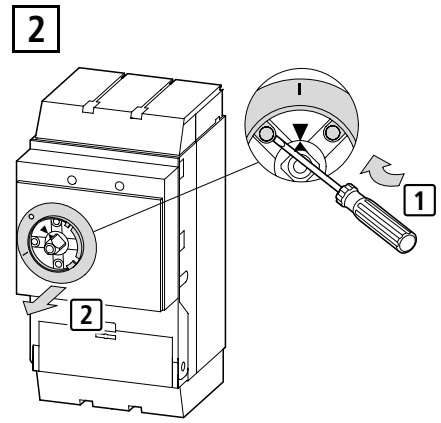
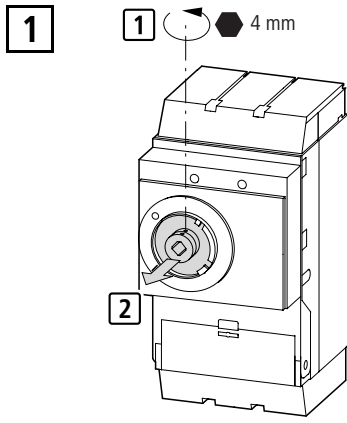
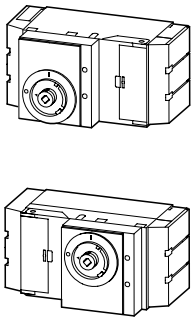

NZM3-XTVDV(R)

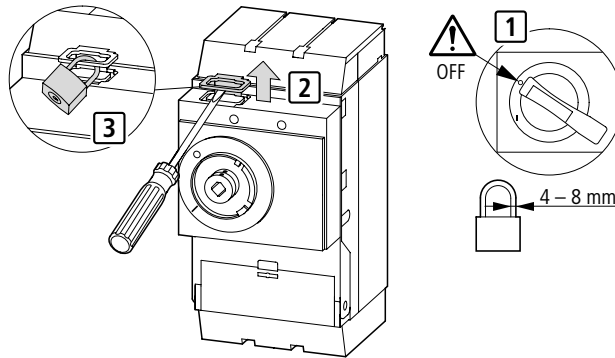

NZM3-XTVD(V)(R)-0

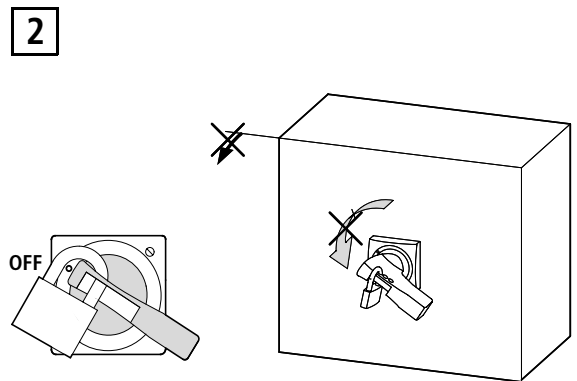
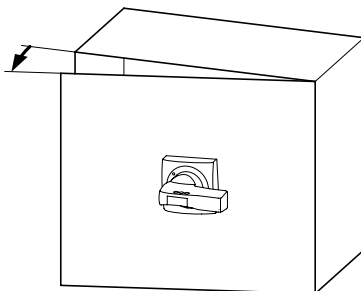
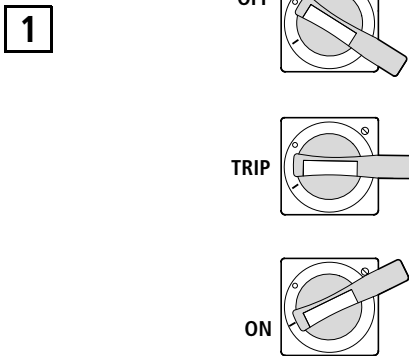

NZM3-XTVD(V)(R)-0-(NA)

1

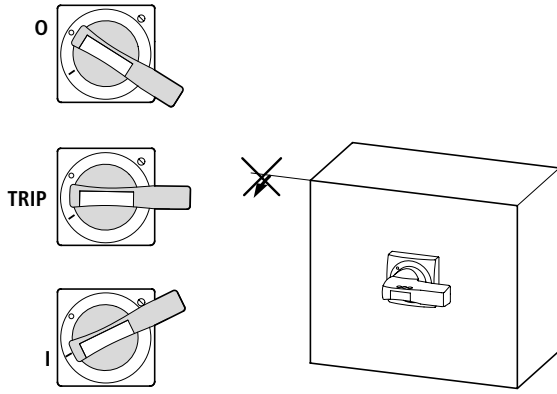

2

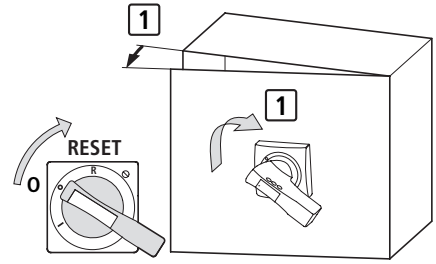

NZM3-XTVD(V)(R)

Aktivierung der Türverriegelung
 Activation of the door interlock
 Activation du verrouillage de porte
 Attivazione del bloccoporta
 Activación del enclavamiento de puerta
 Активирование блокировки дверей
 激活门锁

1

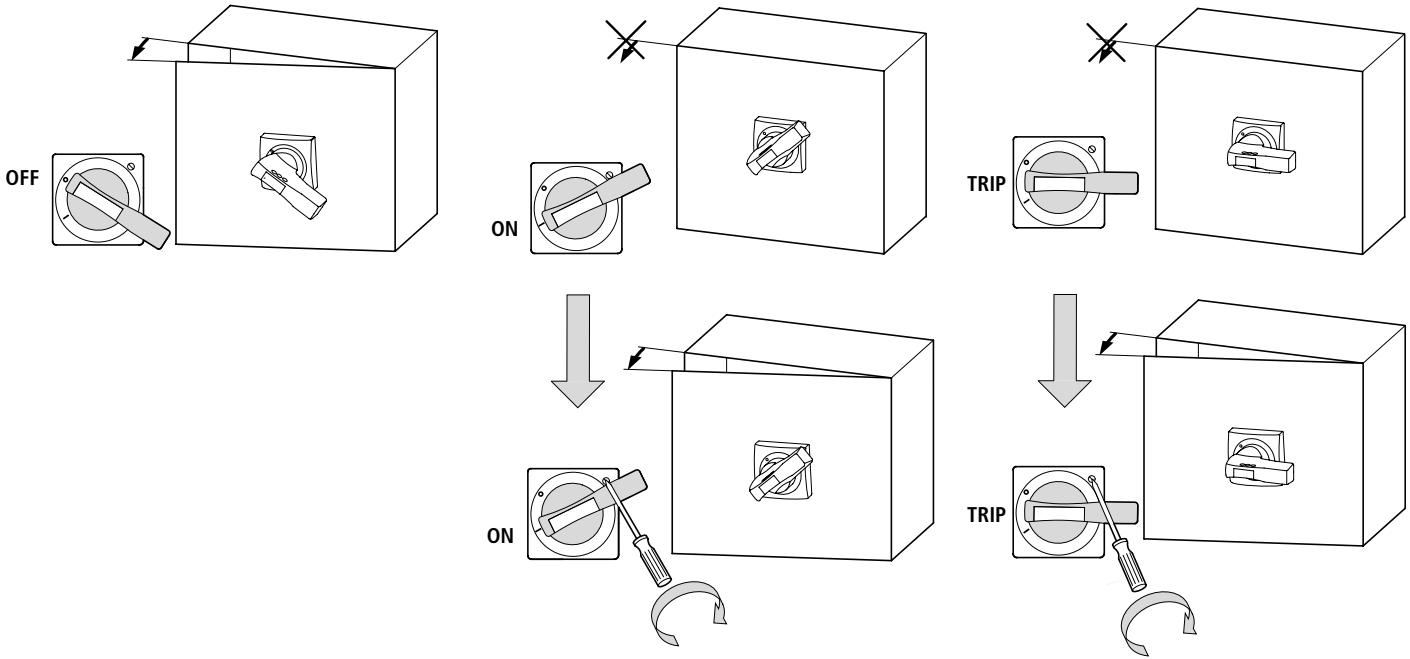
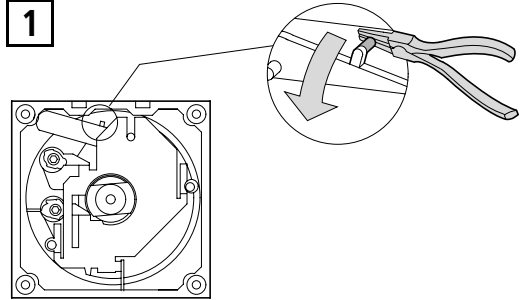

05/06 AWA1230-2124

NZM3-XTVD(V)

Aktivierung der Abschließposition in ON-Stellung – Activation of the locking position in ON position – Activation de la position de verrouillage en ON – Attivazione della lucchettatura nella posizione ON – Activación de la posición enclavable en posición ON – Активирование запирающей позиции в положении ON – 在 ON 位置上激活锁止位置

1

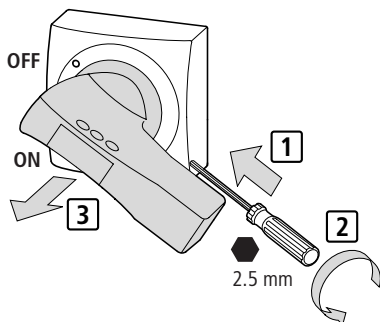

2

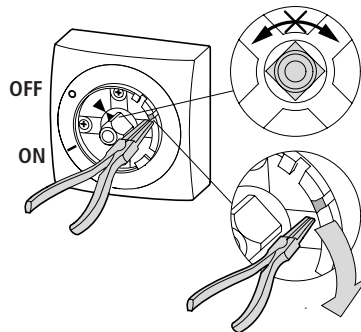

3

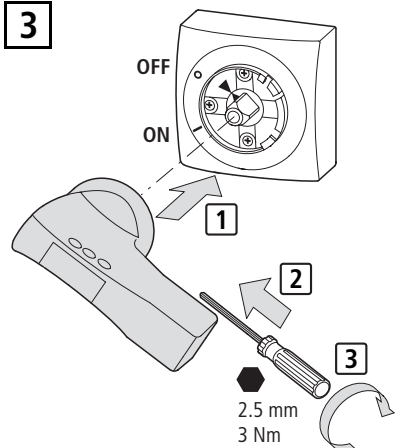

4 TEST

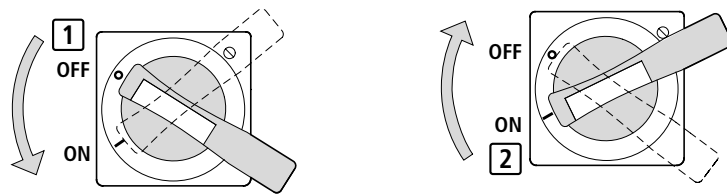

NZM3-XTVD(V)(VR)



Warnung!

Es ist nicht zulässig, die Abschließposition in ON-Stellung für den NOT-AUS zu aktivieren!

¡Advertencia!

¡No está permitido activar la posición enclavable en la posición ON en el pulsador de paro de emergencia!

Warning!

It is not permitted to activate the locking position in ON position for the emergency-stop!

Предупреждение!

Активировать запирающую позицию в положении ON для аварийного отключения не разрешается!

Avertissement !

Il est interdit d'activer la position de verrouillage en ON pour l'arrêt d'urgence !

警告!

不允许紧急停止情况下在 ON 位置上激活锁止位置

Avvertimento!

Non è permesso lucchettare nella posizione ON la maniglia a comando rinviato per arresto di emergenza!

5

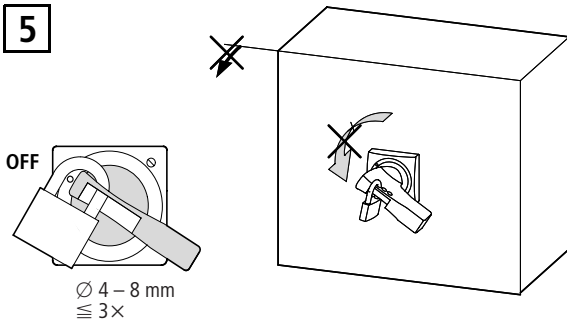

6

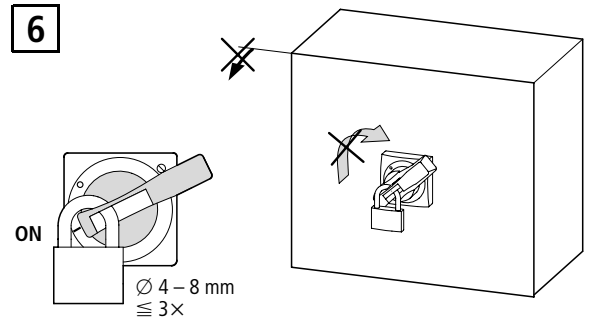

1

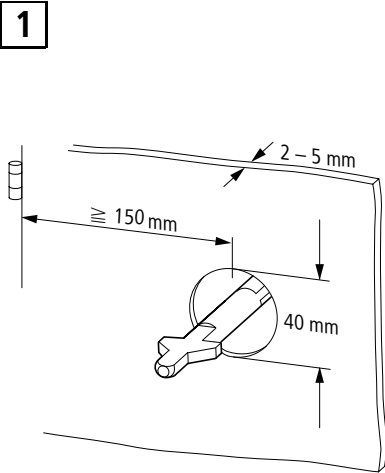

2

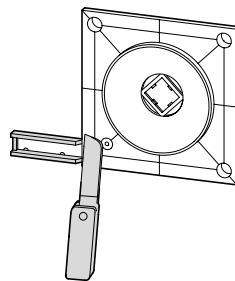

3

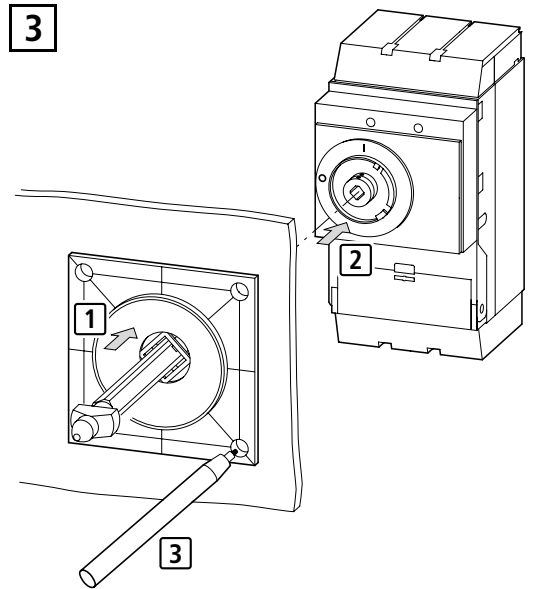

4

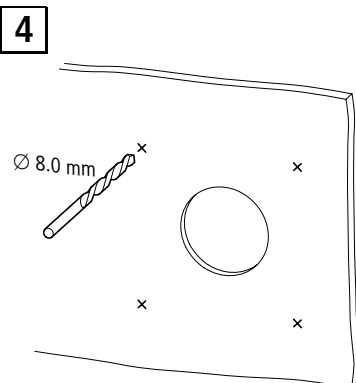

5

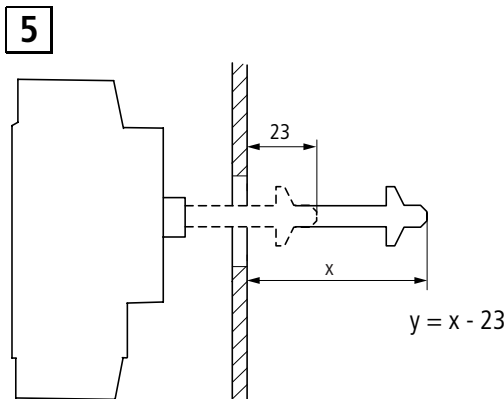

6

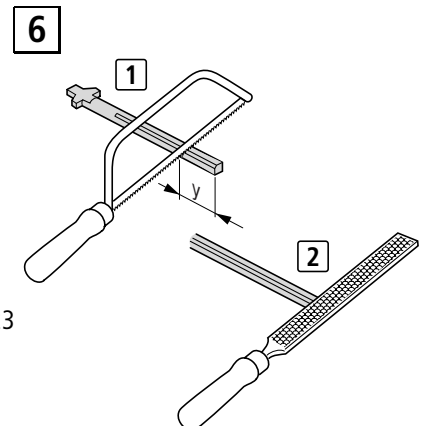

7

