

Mechanical interlock
NZM2-XMV + NZM2-XD

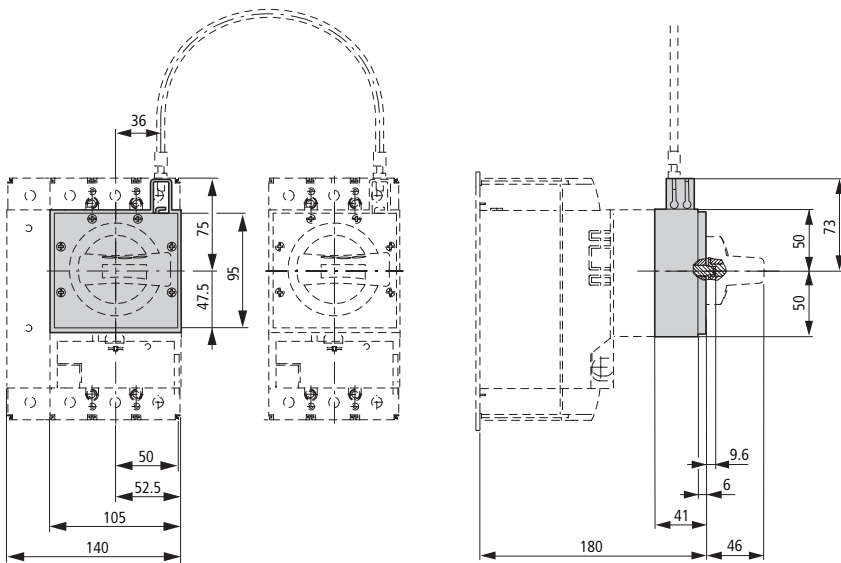

NZM2-XMV + NZM2-XTVD(V)(R)

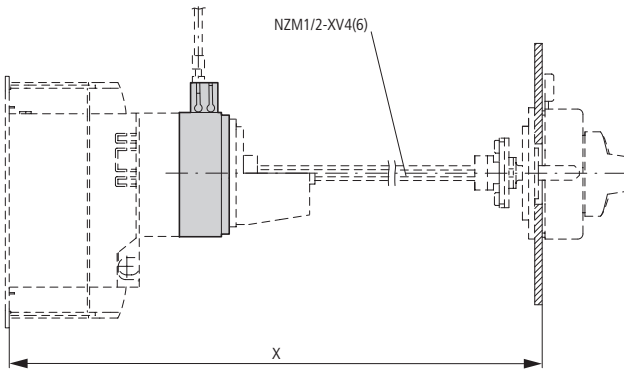

Mechanical interlock

NZM2-XMV + NZM2-XTVD(V)(R)-60

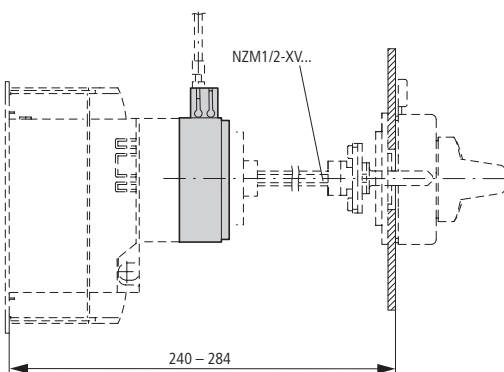

NZM2-XMV + NZM2-XT(V)D(V)(R)-0

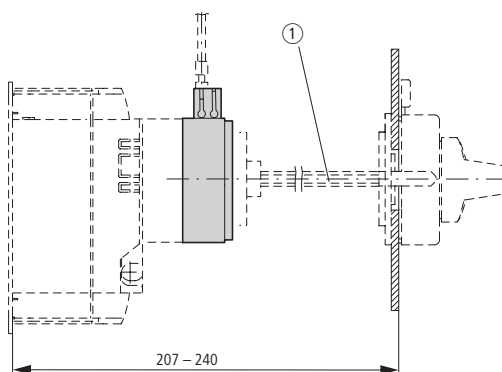

① Special tip

