

Mechanical interlock

NZM1-XMV + NZM1-XDV(R)

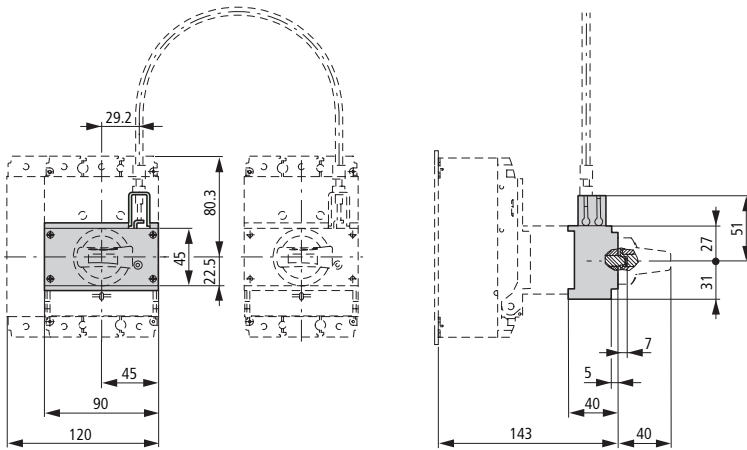

NZM1-XMV + NZM1-XTVD(V)(R)

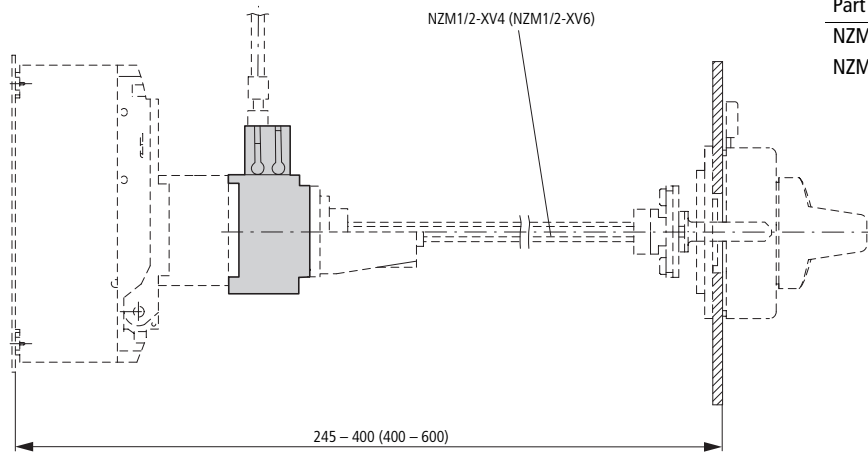

Part no.	x
NZM1/2-XV4	245 - 400
NZM1/2-XV6	400 - 600

NZM1-XMV + NZM1-XTVD(V)(R)-60

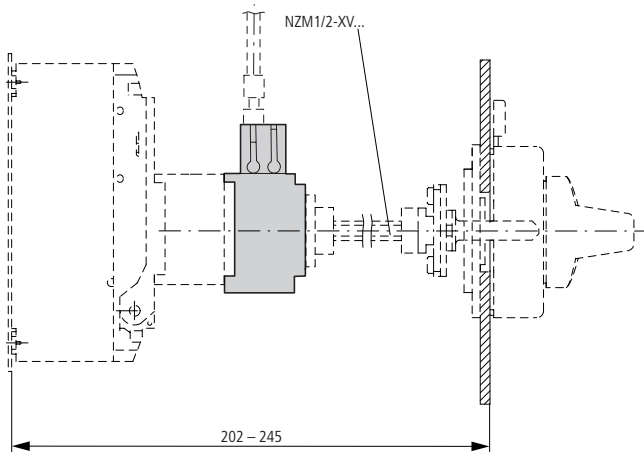

NZM1-XMV + NZM1-XTVD(V)(R)-0

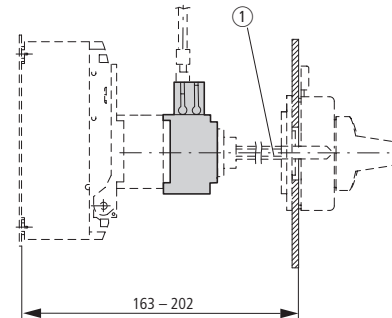

① Special tip